



# Assessing Geoexchange Potential City of Whitehorse, Yukon

**Scott Schillereff, Ph.D., P.Geo., Principal Consultant**  
EBA Engineering Consultants Ltd., Kelowna, BC

**Renewal District Energy in Cities Conference,**  
**VanDusen Botanical Gardens, Vancouver, BC**

*February 28, 2008*

# What is geexchange?

[www.eba.ca](http://www.eba.ca)

**Geexchange** is the coupling of low-grade heat from earth sources (*soil, rock, groundwater, surface water, ocean, waste heat*) which is transformed using heat pump technology to higher-grade heat for building conditioning, domestic hot water or process purposes.

Other names: “geothermal”, “ground source heat pump”, “earth energy systems”



CREATING AND DELIVERING BETTER SOLUTIONS



# Renewable Energy

www.eba.ca

- Earth's surface is a massive **solar collector**
- Geoexchange **moves** renewable solar energy (stored in earth) for beneficial use
- Different from high temperature, deep earth *geothermal* energy (i.e., steam for power generation)
- Electricity is required for geoexchange; may be renewable or not (**electricity** vs. electricity) which affects true source-to-load GHG benefits



CREATING AND DELIVERING BETTER SOLUTIONS



# Components of a Georexchange System

www.eba.ca

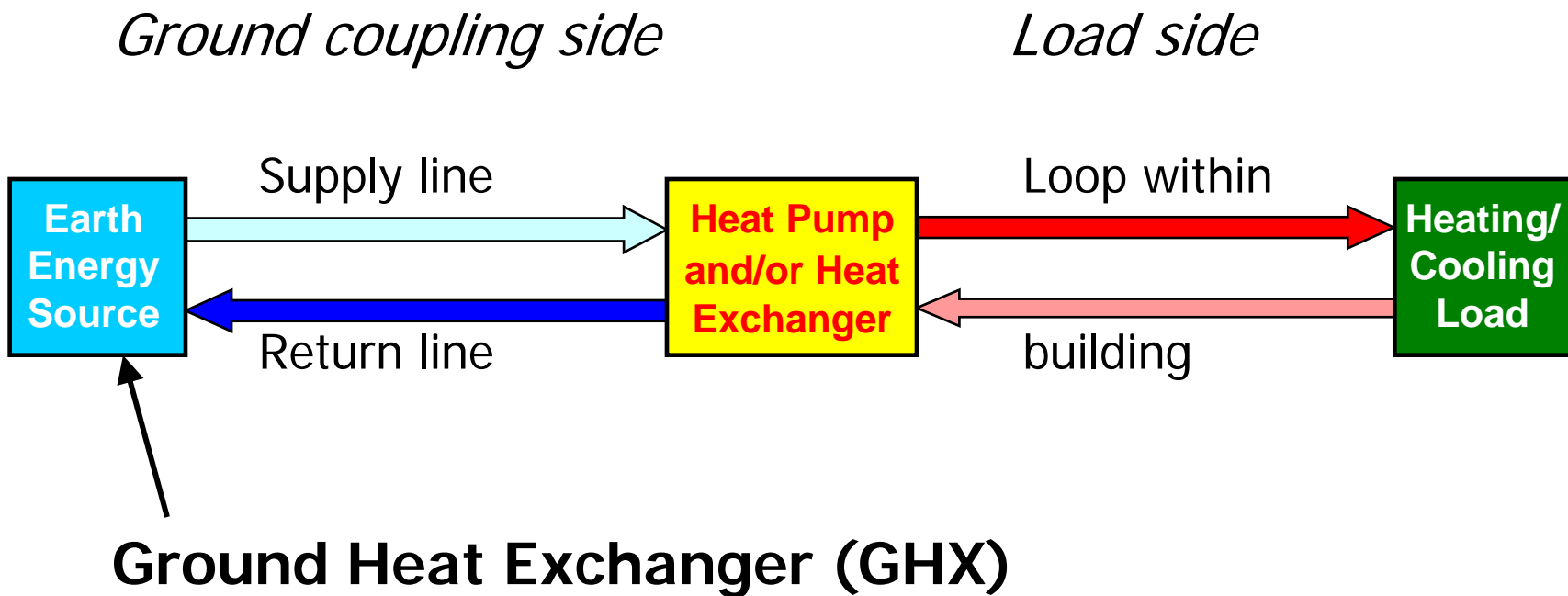

CREATING AND DELIVERING BETTER SOLUTIONS



# Examples of Ground Heat Exchangers

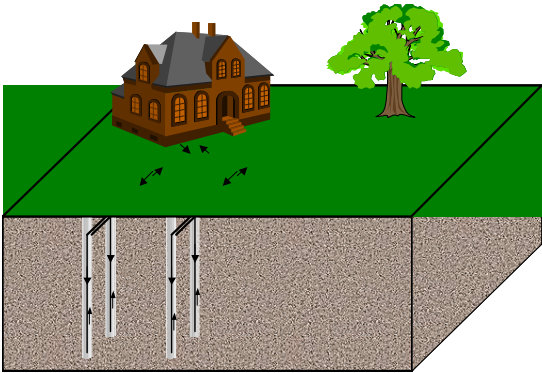

Borehole Closed Loop

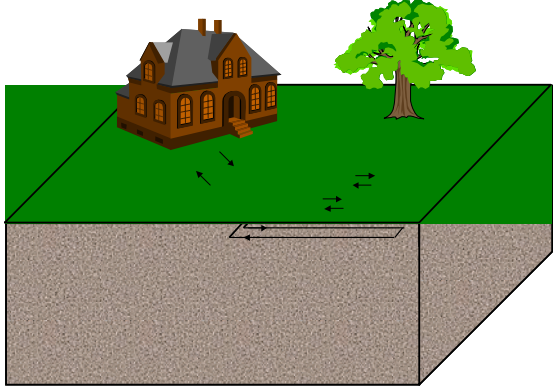

Trench Closed Loop

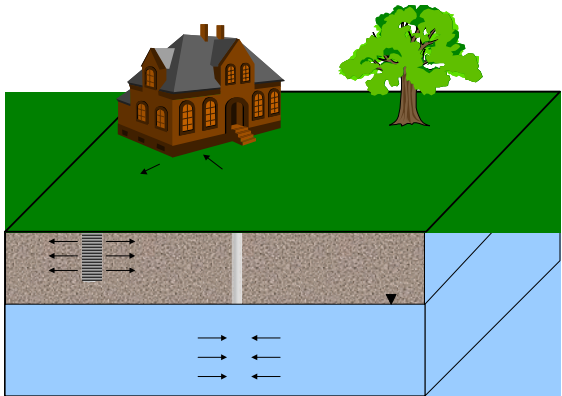

Groundwater Open Loop

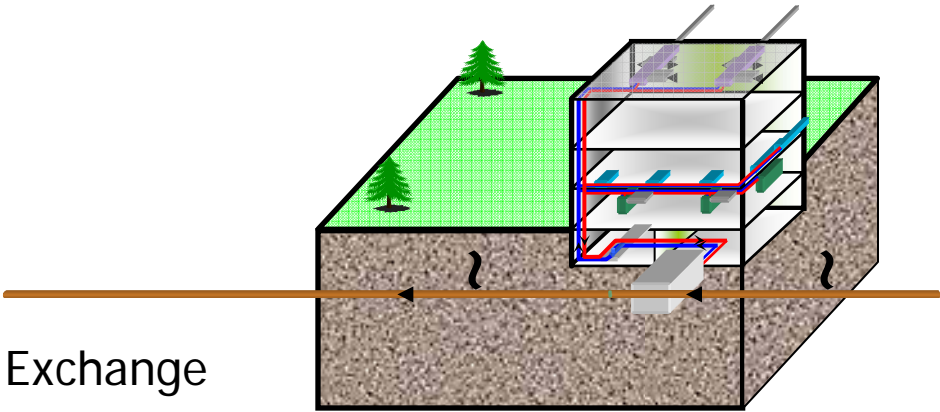

Sewer Heat Exchange



# Hybrid Combinations

www.eba.ca

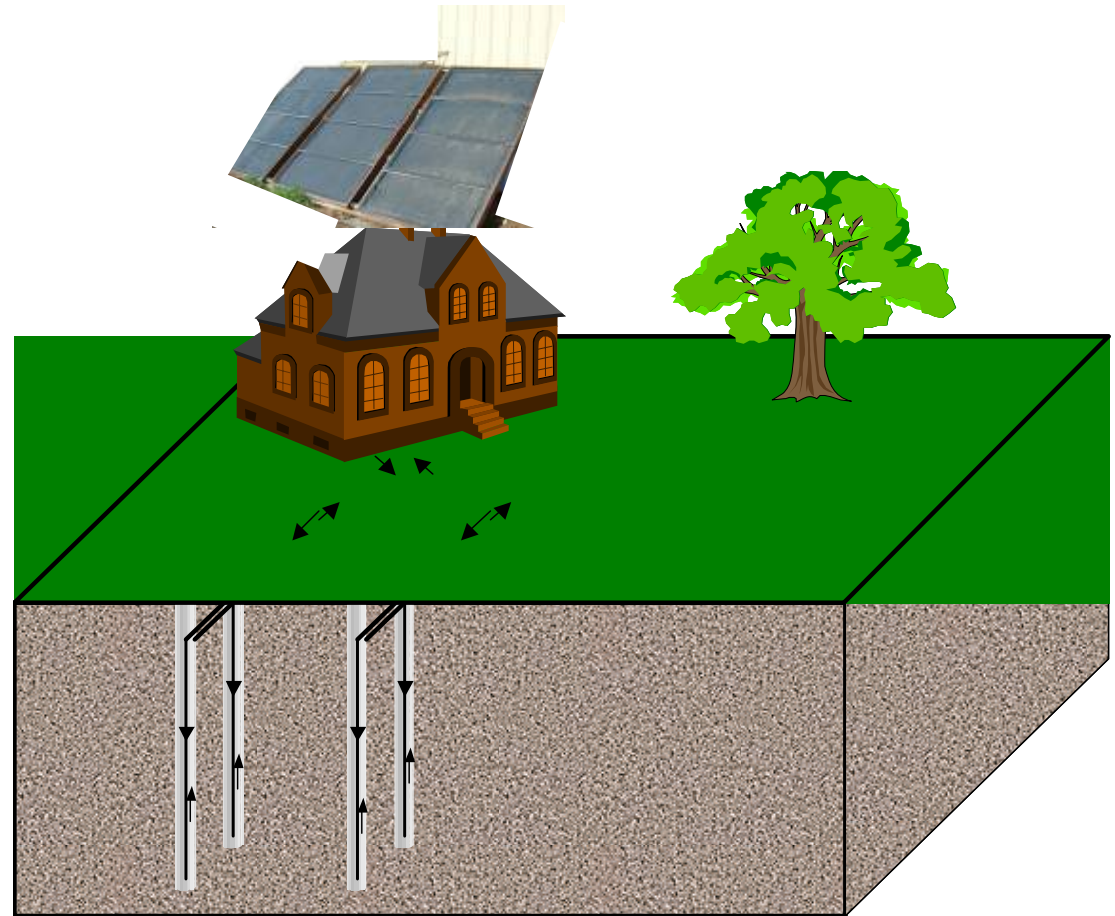

CREATING AND DELIVERING BETTER SOLUTIONS



# Geoexchange Economics

[www.eba.ca](http://www.eba.ca)

**Capital costs** - higher

**Operating costs** - lower

**Simple payback** - variable

**District Energy Systems** – scale often improves economics



CREATING AND DELIVERING BETTER SOLUTIONS



# Geoexchange Suitability Assessment

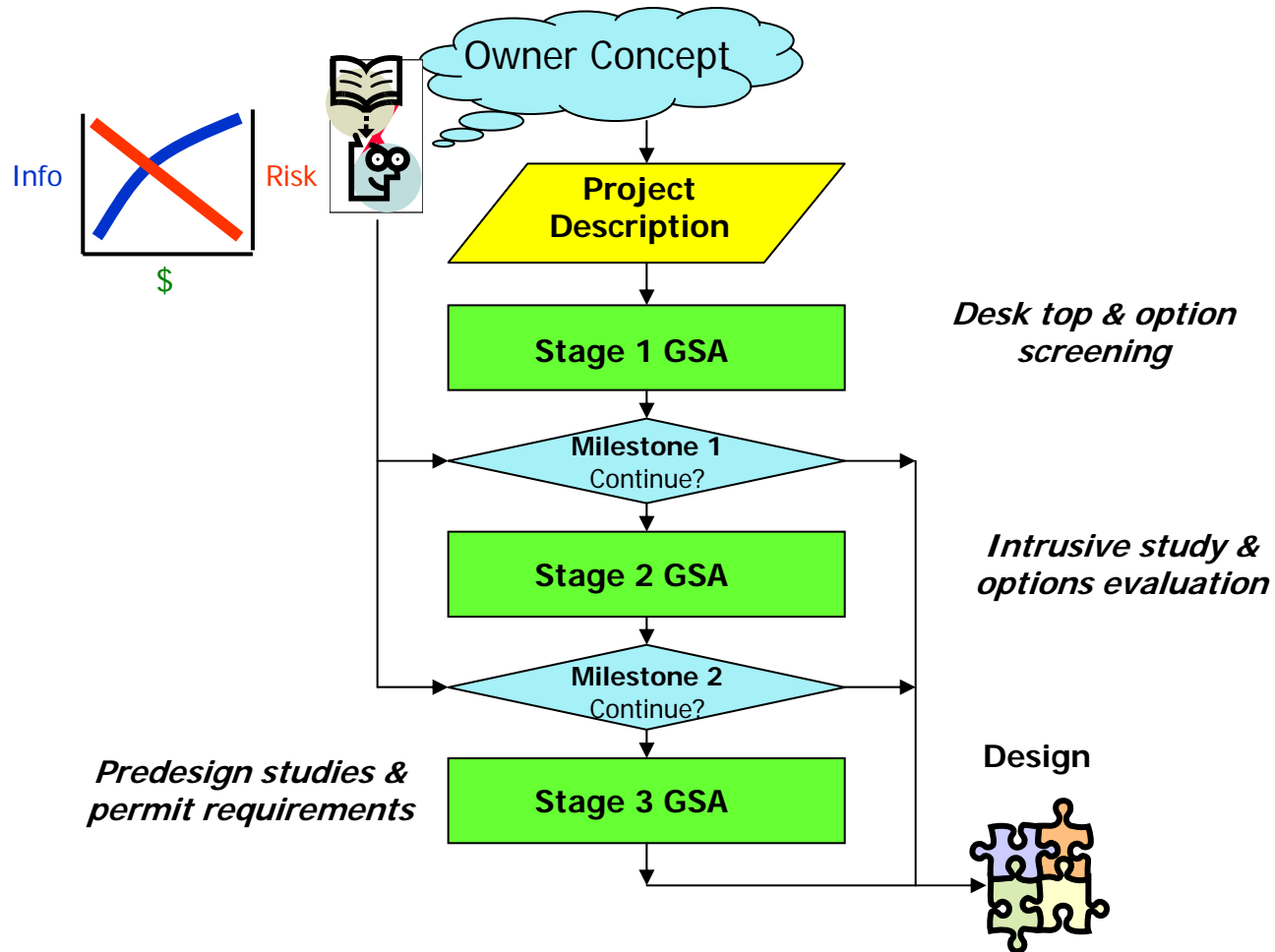

# Neighborhood Scale Systems

www.eba.ca

## Heat transfer within and between buildings:

- Unlike conventional heating/cooling technologies, geexchange systems incorporate a common fluid circulation loop, allowing heat transfer within buildings
- Multiple buildings connected to a common geexchange system allow inter-building heat exchange (**District Energy System**)
- Inter-building heat exchange is most favorable with high load-diversity



CREATING AND DELIVERING BETTER SOLUTIONS



# Georexchange Potential Maps



*Georexchange Potential Maps* were constructed for City of Whitehorse developed & developable areas, and anticipated areas of highest interest in district systems

*Mappable site & land use characteristics*

*Building-specific*

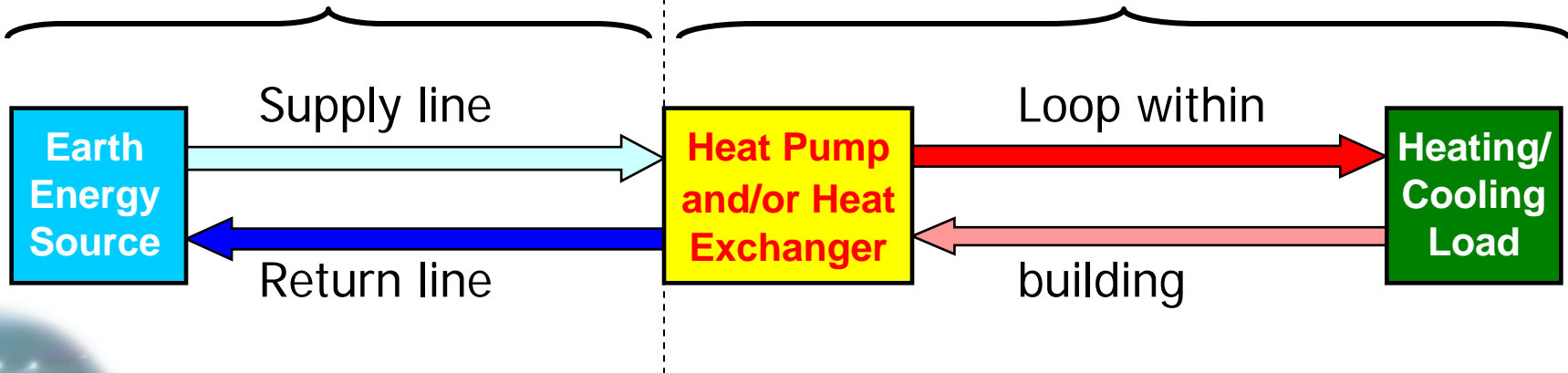

# Geoexchange Potential Maps

www.eba.ca



Maps integrate available and mappable characteristics:

- Location (UTM coordinates)
- Lot size
- Depth to bedrock
- Overburden and bedrock type
- Depth to groundwater
- Thermal conductivity
- Aquifer Transmissivity (Hydraulic conductivity)
- Ease of drilling



CREATING AND DELIVERING BETTER SOLUTIONS



# Geoexchange Potential Maps

www.eba.ca

Maps for three types of ground heat exchanger:

- **Closed loop** vertical borehole systems
- **Open loop** groundwater systems
- **Waste heat** recoverable from sanitary sewers

EBA developed a scoring system to semi-quantitatively evaluate *good*, *fair* and *poor* geoexchange potential

Maps show general favourability of an area for planning

Specific systems require site-specific investigation and design



CREATING AND DELIVERING BETTER SOLUTIONS



# Geoexchange Potential Maps

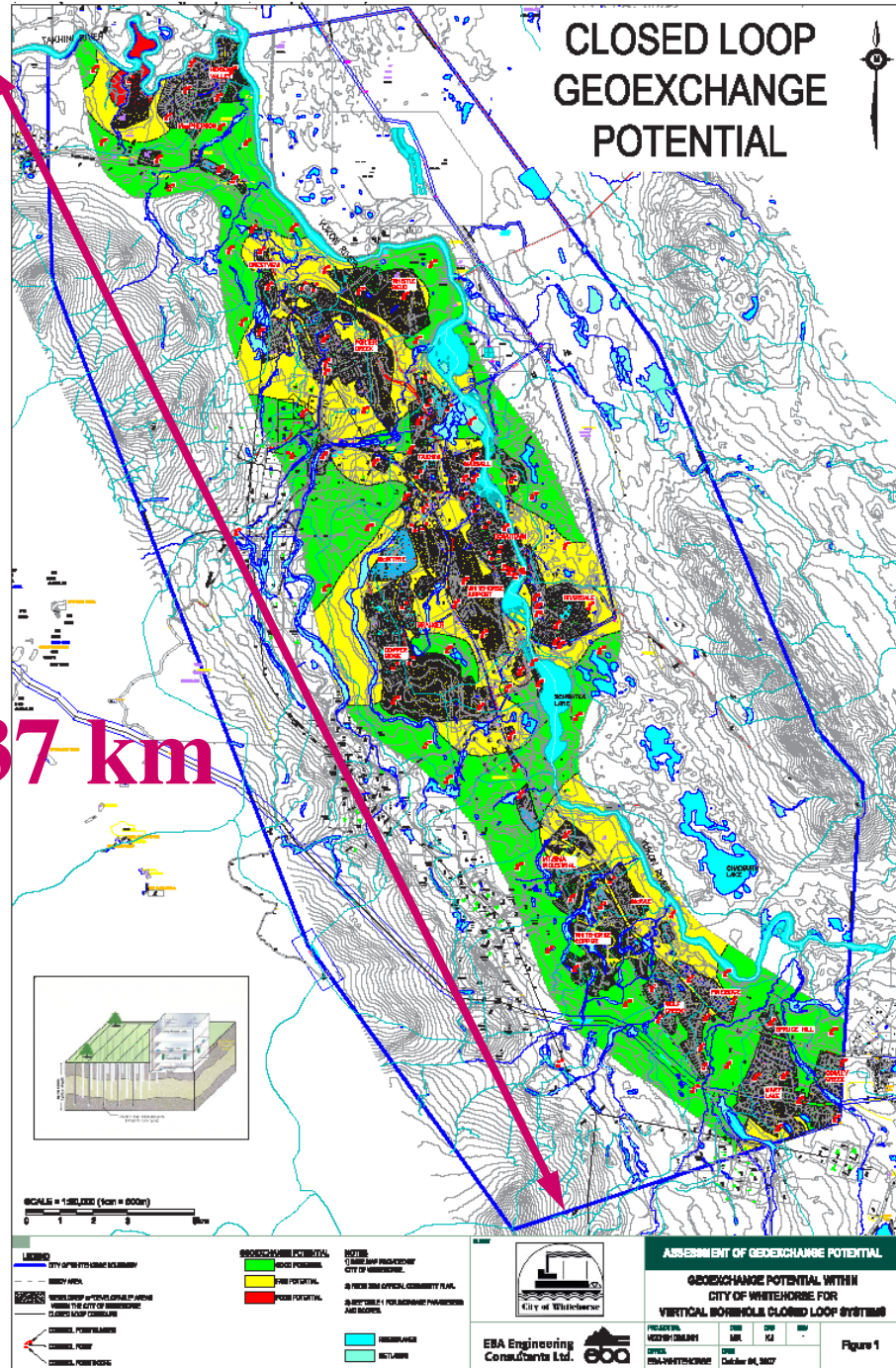
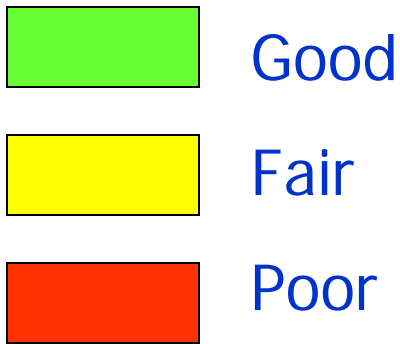

CREATING



# Geoexchange Potential Maps

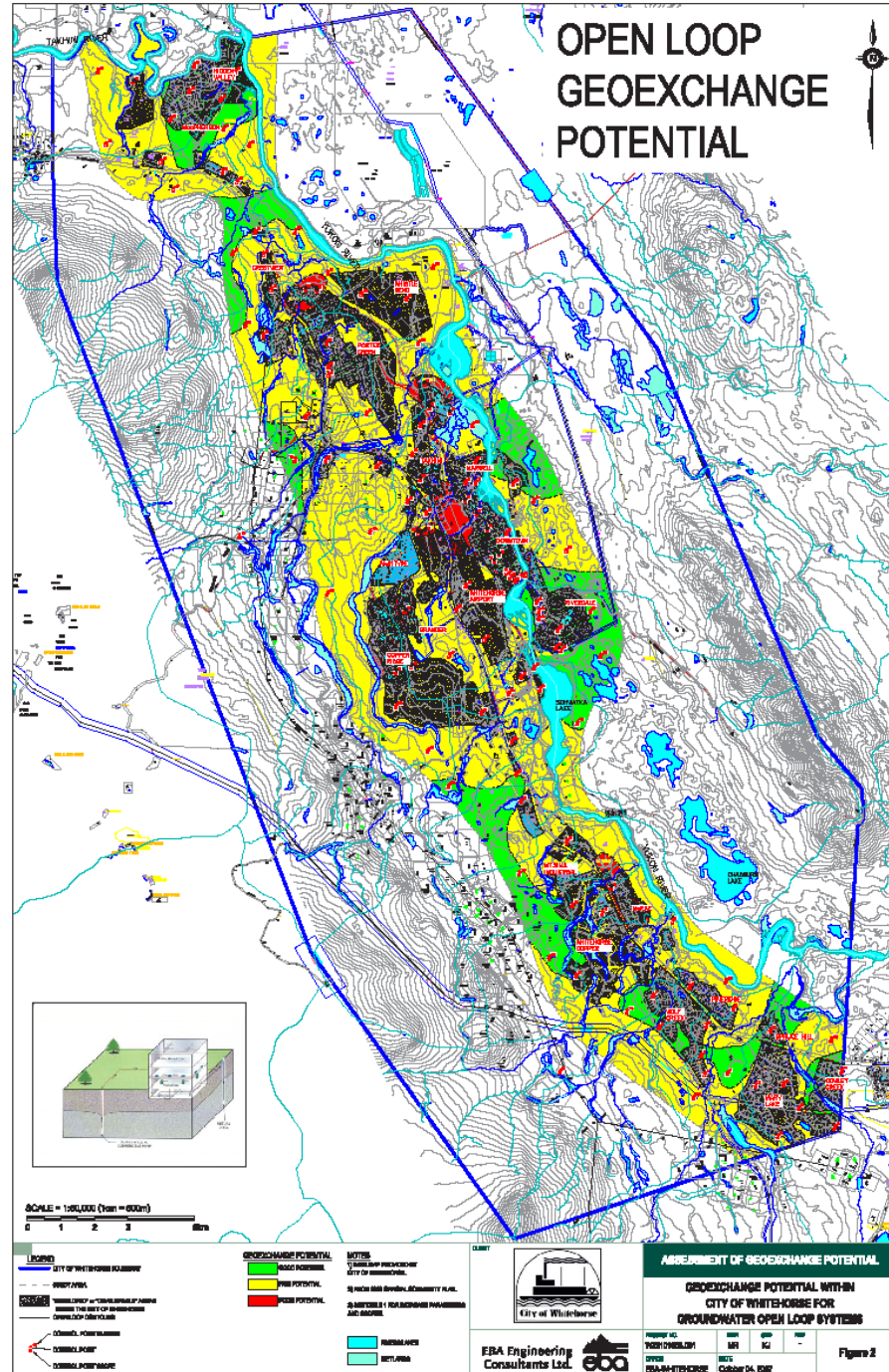

CREATING





# Geoexchange Potential Maps

www.eba.ca



## Findings

- Almost all of City has good to fair closed loop potential
- Most of City has fair to good open loop potential
- Waste heat potential best near largest sewer pipes
- Anticipated demand for local district energy systems in four residential neighborhoods and one industrial park



CREATING AND DELIVERING BETTER SOLUTIONS



# Whitehorse Sustainability Plan

www.eba.ca

Population: 24,360

Land Area: 416 km<sup>2</sup>

Latitude: 60°43'00"N

Longitude: 135°03'00"W



CREATING AND DELIVERING BETTER SOLUTIONS



# Whitehorse Sustainability Charrette

www.eba.ca



- City developing 50-year sustainability plan
- Goal/strategy milestones - 2015, 2030 and 2060.
- Charrette held Oct 22-25, 2007 enabling all citizens to participate



# Who was there?

www.eba.ca

- Residents
- Community Stakeholders
- Governments: City of Whitehorse, Ta'an Kwach'an Council, Kwanlin Dun First Nation, Canada and Yukon
- Local and National experts: sustainability, energy, transportation, health, planning, engineering, arts and culture, environment, climate, economics, sociology and demographics



**80 charrette participants**

**80+ citizens participated in open houses**



CREATING AND DELIVERING BETTER SOLUTIONS



# Media & Geoexchange

## Charrette will yield useful plan, mayor believes

By CHUCK TOBIN  
Star Reporter

Mayor Bev Buckway is optimistic about the week's four-day sustainable planning exercise which concluded Tuesday.

It's not just a charrette conducted by planners and municipal administrators, the mayor emphasized during a press conference Thursday.

"She also described the development of a guiding document developed by professionals from all sorts of disciplines, first nation representatives, the local business community, environmental organizations, stakeholders, and the public.

"This has been very valuable work for the City of Whitehorse," Buckway said. "This is something the community will be able to access as the city moves forward."

The sustainability charrette is intended to produce a 20-year guide, identifying both short-term and long-term sustainable goals, with another years set for 2015, 2030 and 2060.

The mayor was quick to endorse the suggestion the charrette was just another planning exercise.

"City staff will take what has come from the four days and what has been received through public input, either in person or in the e-mail address for Recommendations on the strategy and come up with a document for city council's consideration," she explained.

Buckway said the document will be finalized and the priorities established through a review by council.

It won't have the clout of the city's Official Community Plan, but it will serve as a blueprint of principles the city will use when considering development in general operations and maintenance work, she said.

Buckway pointed out that already there's been a recommendation to



**CHARRETTE SUCCESS** - Mayor Bev Buckway speaks to reporters at the press conference Thursday on the 50-year sustainability charrette.

The exercise looked at transportation issues. The importance of local agriculture was raised as a means of producing local products and lessening the dependency on imported goods, and for its potential as a source of ahead fact.

"Nothing like this has been done in Canada," Buckway said.

The \$380,000 to fund the charrette was provided by federal gas tax money

- diverse local economy;
- equity;
- better environment;
- community development;
- education.

Among those invited to speak at different topics was former Whitehorse resident Chris Dray, who served as executive director of the Yukon Arts Centre for several years and like to move to Ontario in his past summer.

Lovegrove said he was not here to tell city officials what they should or should not do, but to convey what he has seen achieved in other communities.

Bozler, City, for instance, has a similar layout to that of Whitehorse, with similar neighborhoods like Riverdale and Porter Creek, he pointed out. It was not hard with under-use of its public transit system, he said.



GORDON LOVEGROVE



ANDREW CHRASSON

\$12 per individual - is achievable if a similar level of ridership could be maintained, he said.

Similarly, Andrew D. Chasson, a director of geothermal exchange engineering, was invited to talk about the

## Hot stuff: city maps geothermal potential

*"Whitehorse is the first municipality in Canada to undertake a geoechange mapping that identifies potential heat sources within our ground that we can use to our benefit for our buildings."* - Mayor Bev Buckway

By Matthew Grant  
Star Reporter

In an effort to keep our homes warmer in an environmentally sensitive way, Whitehorse has become the first Canadian city to map the earth's heat.

The Whitehorse-style geothermal map came out of a sustainability charrette held this week. There, more than 80 experts, politicians and citizens developed green strategies that will guide the city for the next 50 years.

"Geothermal systems lay the best of the earth to provide commercial and residential properties with hot water and hot and cold air."

"Whitehorse is the first municipality in Canada to undertake a geoechange mapping that identifies potential heat sources within our ground that we can use to our benefit for our buildings," said Mayor Bev Buckway on Thursday.

"That really strengthens the innovation that the city is well known for."

The "guiding principles," including ideas for geothermal

heating bills, and Andrew Chasson, a geoechange engineer with EBA environmental consultants in Kelowna, B.C., and a charrette consultant.

"As far as energy savings, geothermal saves anywhere from 40 to 80 per cent of annual energy that we're actually consuming."

"How that translates into actual dollars and cents depends on how you're heating."

"If you're heating with electricity versus heating with that oil, each one of those methods of heat has their own cost."

The geothermal map itself will help officials decide what areas of the city are good candidates for geothermal heating, and which aren't, he said.

"To describe what (the map) is first of all it's a geoechange (feasibility, or potential, map)," said Chasson.

Solar and wind energy potential has been well studied and documented.

Geothermal potential has not, he said.

"That has not been studied, or you can look at a map and say 'Yuk, it looks like it's not,'" he said.



**SUSTAINABLE DEVELOPMENT.** The City of Whitehorse hosted a charrette this week to plan green strategies for the next 50 years.

ing into the ground, he said.

The charrette itself cost \$100,000 and included transportation, global warming, geothermal and planning experts working with members of the community, said Lindsay Caborn, the city's integrated community sustainability coordinator.

"That (cost) includes all our consultant contracts," she said. The \$100,000 comes from the federal government's gas tax program, which uses a portion

of the work accomplished over the week will be posted on the city's website, including a new interactive website tool — <http://whitehorse.ca/energy> — that displays what the city's sustainability goals are.

All the presentations are on the city's website," said Caborn. Sustainability goals for the city identified by charrette participants vary, according to the website.

They include land and infrastructure efficiency.

The principles identified by the charrette stakeholders will be used to guide the development goals and strategies for the community for the next 50 years, according to the city.

This long-term vision also includes a seven-year strategic plan, which the city will use to identify specific projects.

Charrette participants also included local citizens, repre-

- Geoexchange concept embraced by community.
- Identified neighborhoods/new areas to use geoechange



# What works/ what doesn't



[www.eba.ca](http://www.eba.ca)

- Maps in stop light colours – intuitive
- Map uncertainty relates to density of subsurface information
- Ground temperature & GW chemistry yet to be mapped
- Mass appeal of geoexchange technology but gaps in public understanding



# Lessons learned

www.eba.ca

- Strong caution *not* to rely on such areal maps for design or future performance; site-specific work needed
- Municipality must have long-term sustainability position to see district energy projects through
- People flock to colourful maps



# Applicability to BC Local Gov

www.eba.ca

- Readily applicable to BC at municipal and regional district scales
- Can be tailored to development corridors (trans-boundary)
- Can be applied for hybrid technologies (e.g., geexchange + solar thermal)
- Fits well with provincial policy and strategic direction (LiveSmartBC: Efficiency Incentive Program?)



# Moving Forward

- Broadcast concept and value of renewable energy resource mapping – conferences, UBCM, UDI, CEA, trade magazines, newspaper articles
- Seek pilot project(s) in BC – who wants to be first?

